



keonn

Retail RFID
Systems

AdvanLook™

Interactive product
recommendation system





Video

Benefits:

- Increases sales by 25% at retail stores
- Increases conversion rate
- Increases cross-selling
- Improves the customer shopping experience
- Provides recommendations
- Fun to use
- Advertising space
- Generates information about user interests
- The frame colour and material can be chosen
- The content and user interface can be updated remotely

Applications:

- Retail stores
- Libraries
- Museums

Product overview

AdvanLook is a **product recommendation** and **cross-selling system** for retail stores.

AdvanLook uses RFID technology and an interactive screen to improve the shopping experience of customers at retail stores or libraries.

Customers see images of the products they have picked up, detailed information about these products and receive product recommendations.

AdvanLook **increases the sales of retailers by 25%!**

AdvanLook comes in three sizes:

- 10" touch screen
- 20" touch screen
- 43" touch screen

The **use process** is as follows:

1. The customer picks an item he or she finds interesting
2. The customer approaches the product to AdvanLook, and the RFID subsystem of AdvanLook detects it
3. The screen of AdvanLook shows images of the product, together with information like colours and sizes available, composition, price, etc. The customer also receives recommendations of matching products and accessories
4. With AdvanLook touch screen, the customer can browse through other products, request that an employee brings one product, etc.

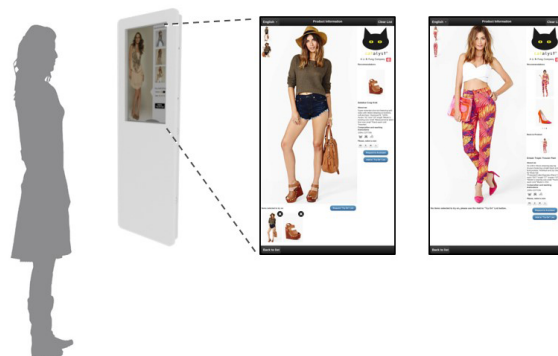

Thanks to its simplicity and price, several units can be installed in one store.

AdvanLook **comprises**:

- RFID subsystem, with two antennas
- Touch screen
- Screen frame
- Embedded computer
- Content and user interface management cloud-based software

The color and material of the **frontal frame** can be selected.

Connection to AdvanCloud

The content and user interface of AdvanLook can be updated remotely very easily, by means of the **AdvanCloud cloud-based software**.

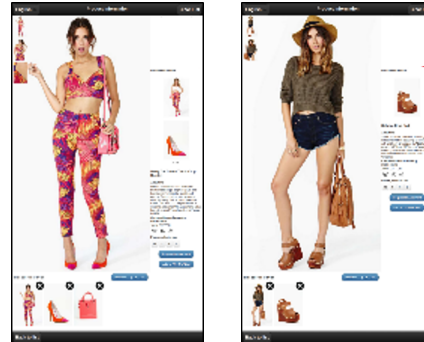
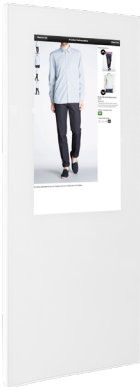

All the events are registered and stored in AdvanCloud. This information can then be analysed for **business intelligence** purposes:

- Number of users that use AdvanLook
- Products that customers bring to AdvanLook
- Recommended products that customers select on the screen
- Products that the customers request to be brought by an employee
- Etc.

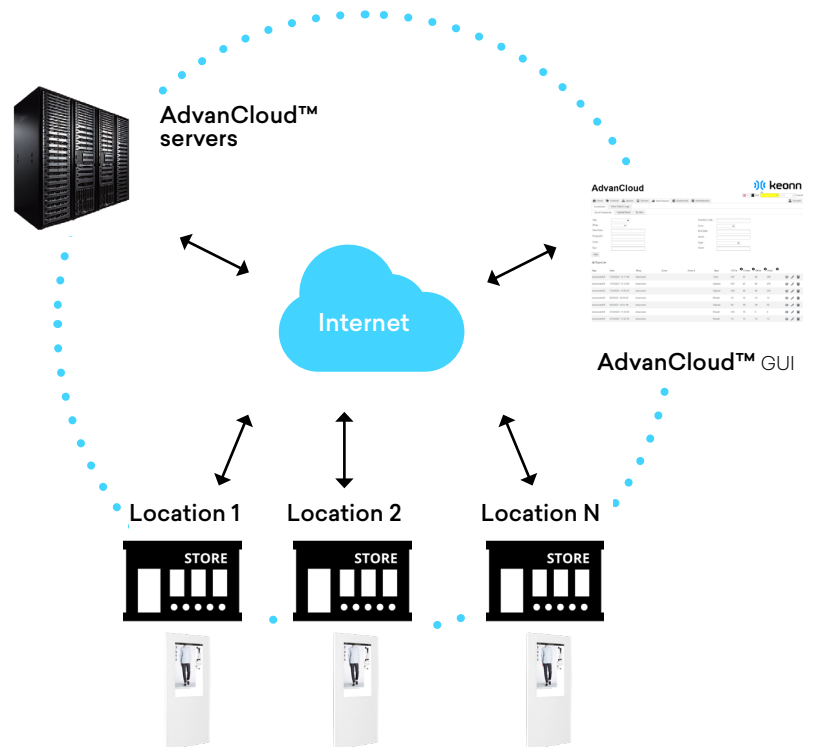



Finishing options for the frame (for 10")

Default finish	Black shiny methacrylate and RAL 9005 microtextured
----------------	---

Finishing options for the frame (for 20", 43")

Options	Metallic frame and structure available the whole RAL palette. For other finishes like chrome, gold, graphite, etc., please ask the commercial team
Default finish	Matt micro textured powder paint in RAL 9016

Common technical specifications

Touch screen technology	Projected capacitive
RFID frequency EU Version	865,6 - 867,6 MHz (ETSI EN 302 208)
RFID frequency US Version	902 - 928 MHz (FCC part 15)
Standard Compliance	EPCglobal Gen2 (ISO 18000-6C)
RFID Antennas polarization	Circular
Temperature range	0°C to +40°C

Technical specifications of AdvanLook 10" wall mount

RF Power output	Programmable from 0 dBm to 27 dBm in 0.5 dBm steps
Screen size	10 inches
Weight	1,05 Kg

Technical specifications of AdvanLook 10" desktop

RF Power output	Programmable from 0 dBm to 27 dBm in 0.5 dBm steps
Screen size	10 inches
Weight	2.54 Kg

Technical specifications of AdvanLook 20"

RF Power output	Programmable from -5 dBm to 30 dBm in 0.5 dBm steps
On board sensors	Ultrasound distance sensor
Screen size	20 inches
Weight	14.5 Kg

Technical specifications of AdvanLook 43"

RF Power output	Programmable from -5 dBm to 30 dBm in 0.5 dBm steps
On board sensors	Ultrasound distance sensor
Screen size	43 inches
Weight	39 Kg

Mechanical specifications of AdvanLook 10" wall mount

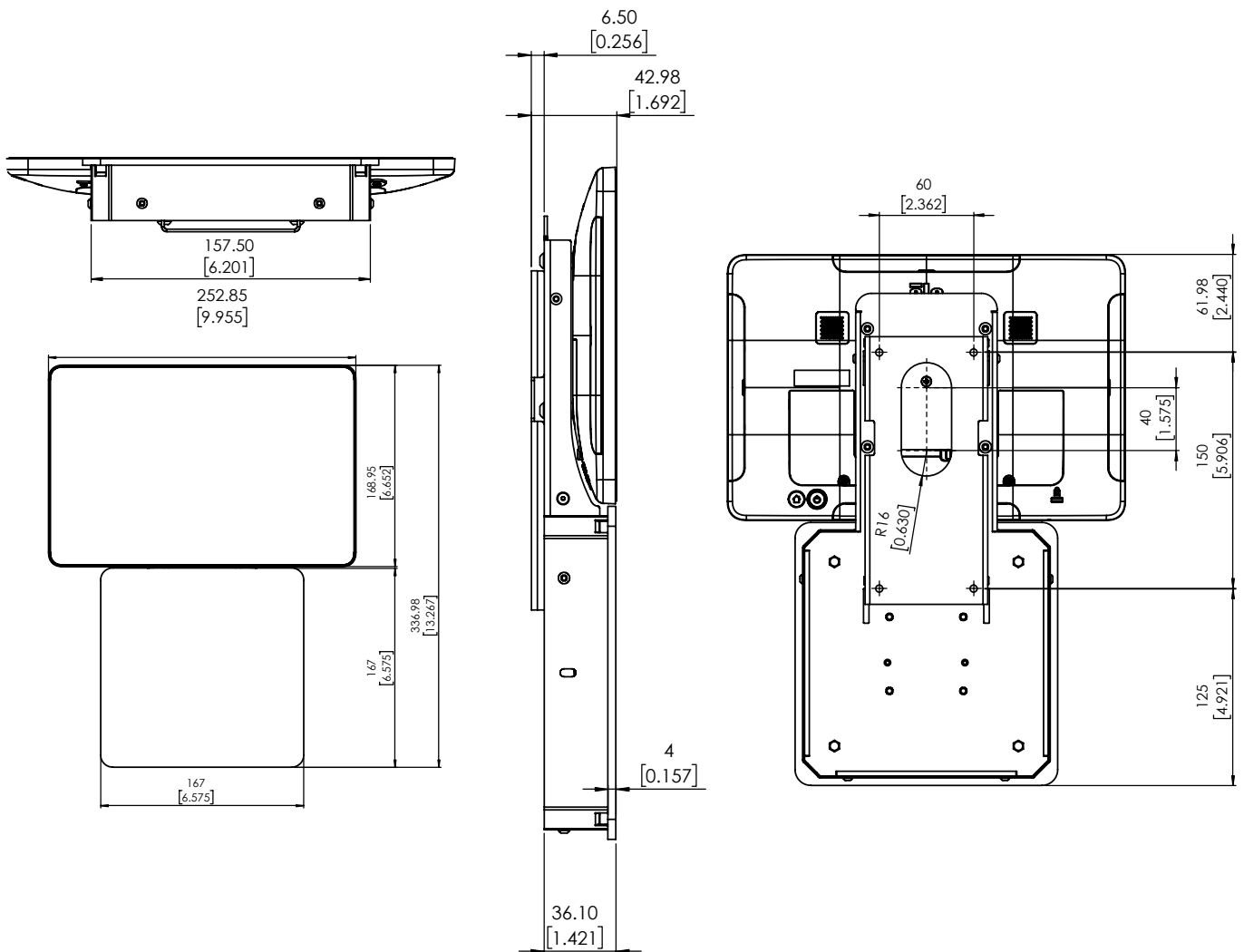
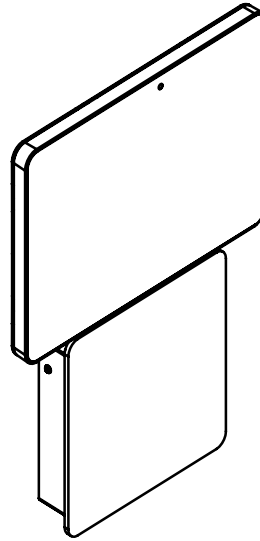

Units in millimeters and [inches]

Mechanical specifications of AdvanLook-10" desktop

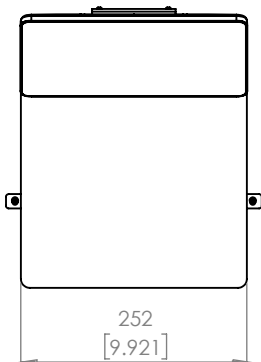
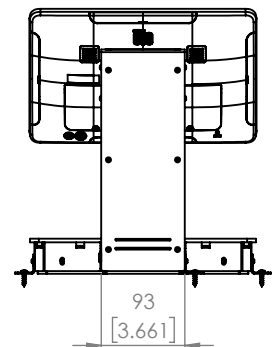
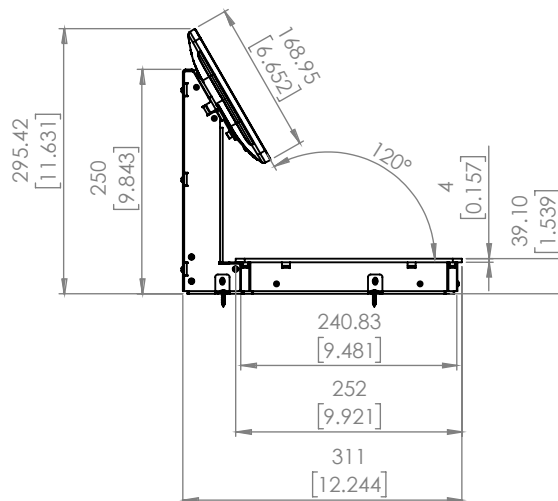
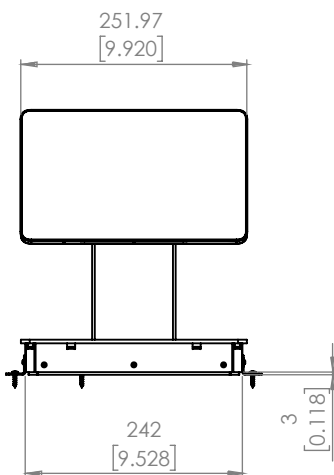
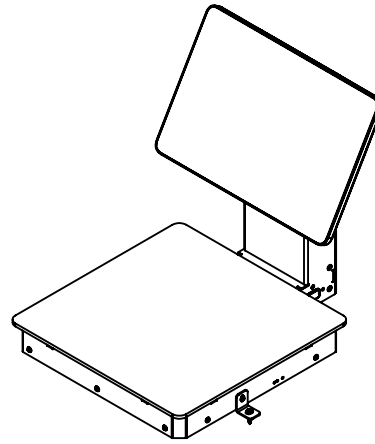

Units in millimeters and [inches]

Mechanical specifications of AdvanLook 20"

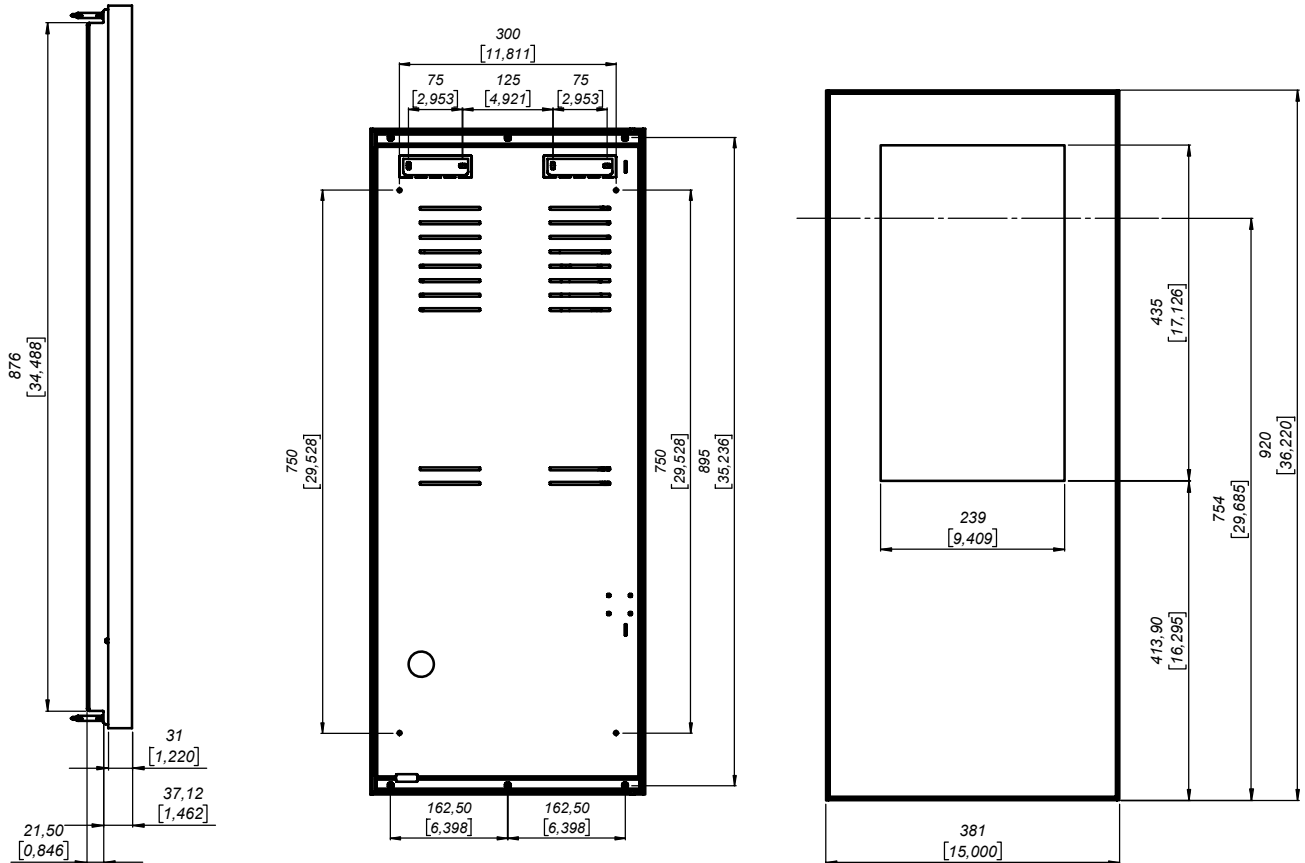
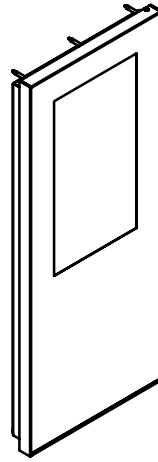

Units in millimeters and [inches]

Mechanical specifications of AdvanLook 43"

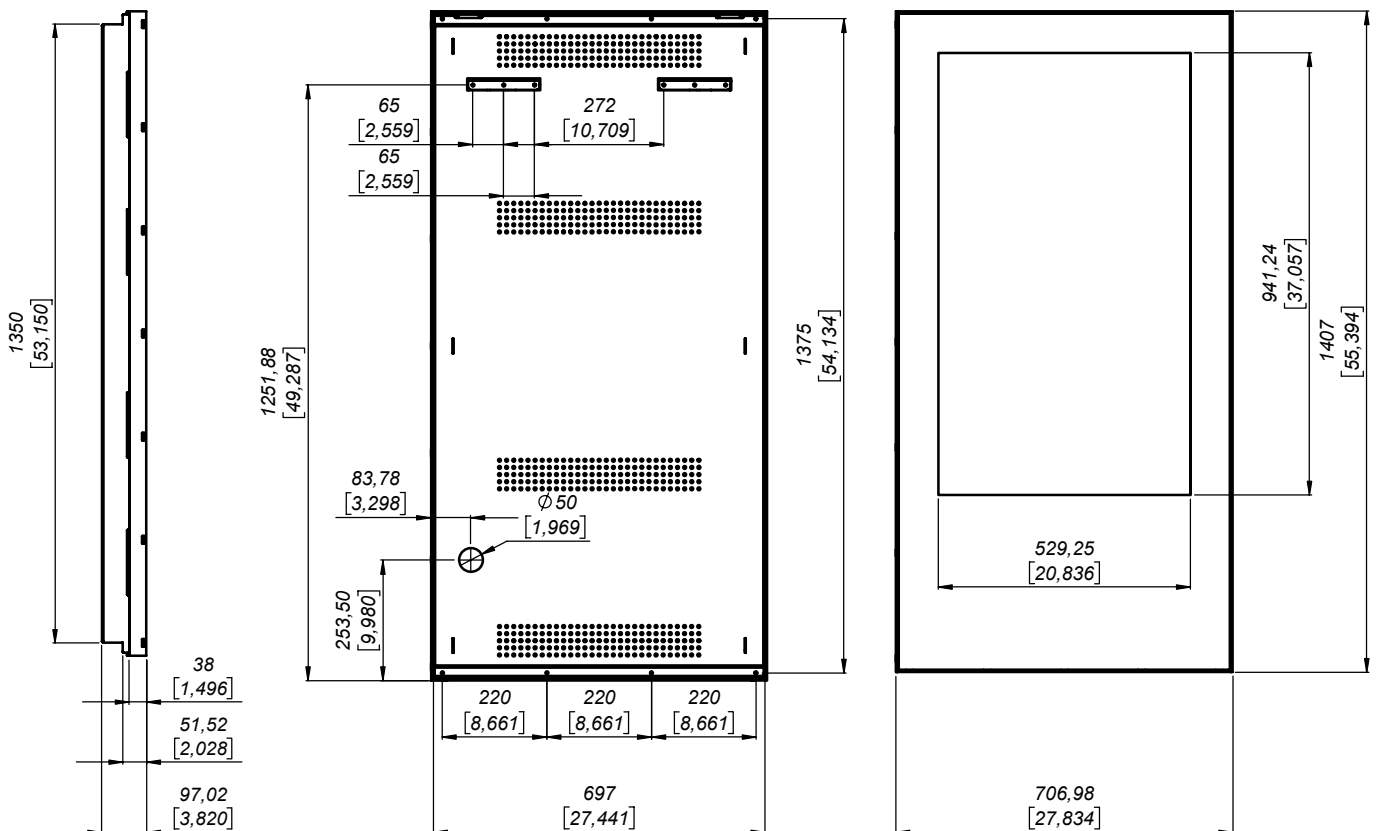
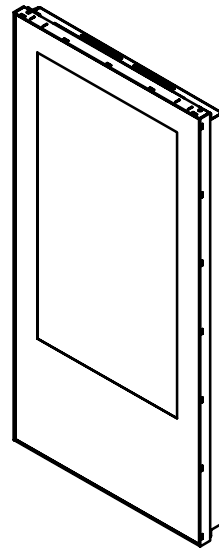
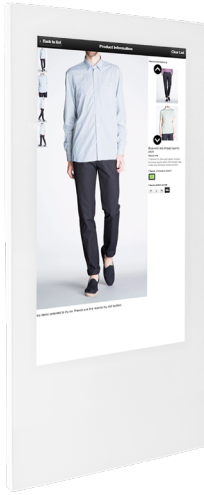

Units in millimeters and [inches]

Product codes for ordering

ADLK	-	SS	O	-	DK	-	FF	-	mmm	
										SS = screen size
		10								10 inch
		20								20 inch
		43								43 inch
										O = Options
			T							Touch screen
			TW							Touch screen with WiFi (10")
										DK = Desktop
					LT					For 10" desktop
										FF = frequency band
							EU			865.6 MHz – 867.6 MHz
							US			902.0 MHz – 928.0 MHz
										mmm = model
									100	Model Nr. for 10" version
									300	Model Nr. for 20" and 43" version
									210	Model Nr. for 10" desktop mount

Examples:

ADLK-20T-US-300:

- Advanlook
- Frequency band : 902,0 MHz - 928,0 Mhz
- **20"**
- **Touch** screen
- Model **300**

ADLK-10TW-EU-100:

- AdvanLook
- Frequency band : 865.6 MHz – 867.6 MHz
- **10"** screen wall mount
- Touch screen with WiFi
- Model **100**

ADLK-10TW-LT-EU-100:

- AdvanLook
- Frequency band : 865.6 MHz – 867.6 MHz
- **10"** screen desktop
- Touch screen with WiFi
- Model **100**



Copyright © Keonn Technologies S.L.
All rights reserved.

Information in this publication
supersedes all earlier versions.
Specifications subject to change
without notice.

